

INSTRUCTIONS FOR MMTL-5977

1. REMOVE MMSP HEAD BY UNSCREWING NUT.
2. PLACE EITHER THE INSULATOR TIP OR THE CONTACT TIP INTO MMSP FEMALE HEAD (NOTICE ORIENTATION).

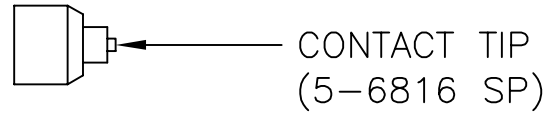

3. SLIDE NUT OVER MMSP HEAD AND THREAD NUT ONTO MOUNTING SLEEVE, UNTIL HEAD IS BOTTOMED OUT.
4. TURN ON THE GAGE.
5. ZERO THE GAGE BEFORE USE BY GENTLY INSERTING THE ZERO OUT TOOL (5-6820 XX) INTO THE MMSP HEAD OF DIAL. WHILE IT IS FULLY INSERTED PRESS THE YELLOW ZERO BUTTON.
6. PLACE MMSP FEMALE CONNECTOR INTO MMSP HEAD UNTIL CONNECTOR STOPS AGAINST THE HEAD AND RECORD RESULTS. (POSITIVE VALUE INDICATES PROTRUSION RELATIVE TO CONNECTOR R/P.)

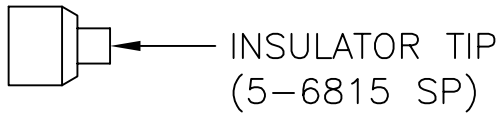
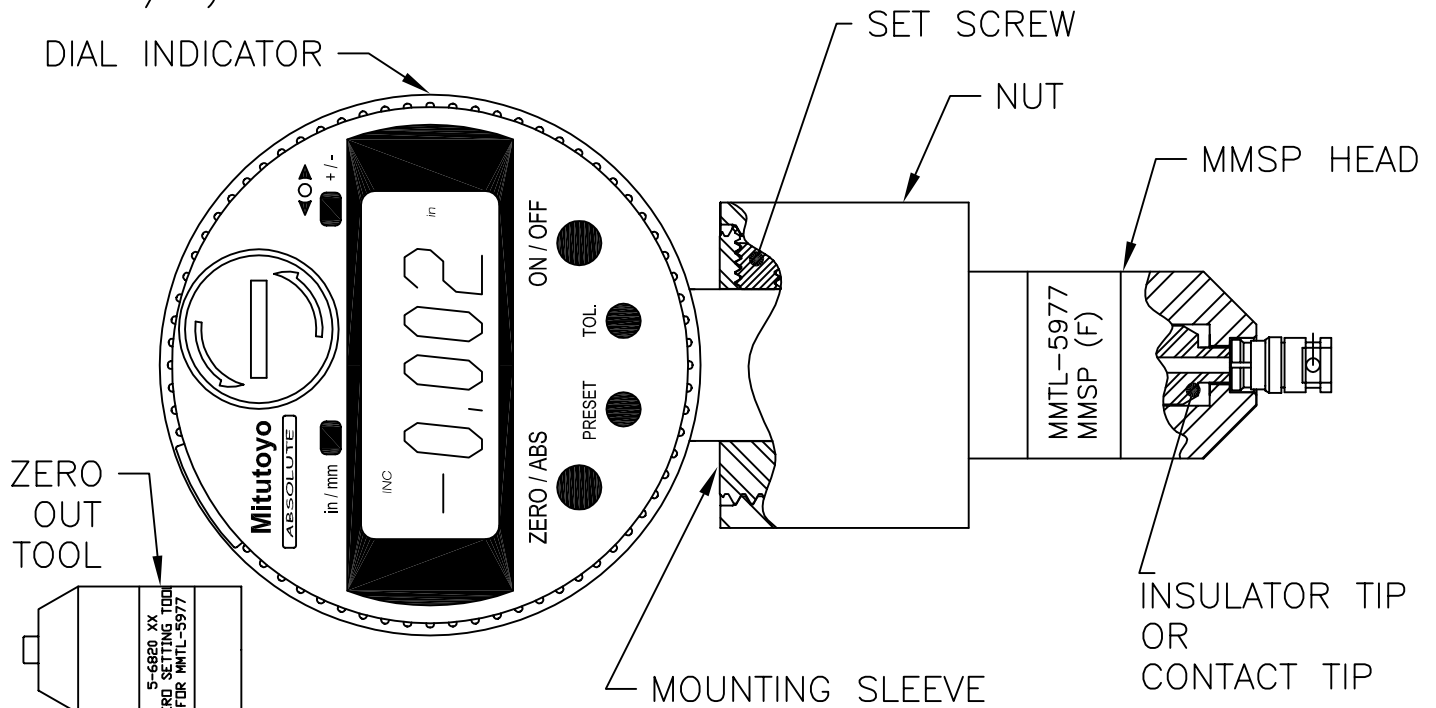

MICRO-MODE PRODUCTS, INC.
The Reliable Connection to the Future

El Cajon, CA 92020
 ph 619.449.3844
 www.micromode.com

CAGE CODE
 15907

REF: .	INSTRUCTIONS FOR MMTL-5977	
DEFAULT TOLERANCES: .XXX ± .005 .XX ± .01	PART NO.	REVISION
SHEET 1 OF 1	OL6821 06-04-03 MT	MMAP-6821 —